



UNISORB Vector Bolts™ & Grout

Machinery Anchoring and Grouting

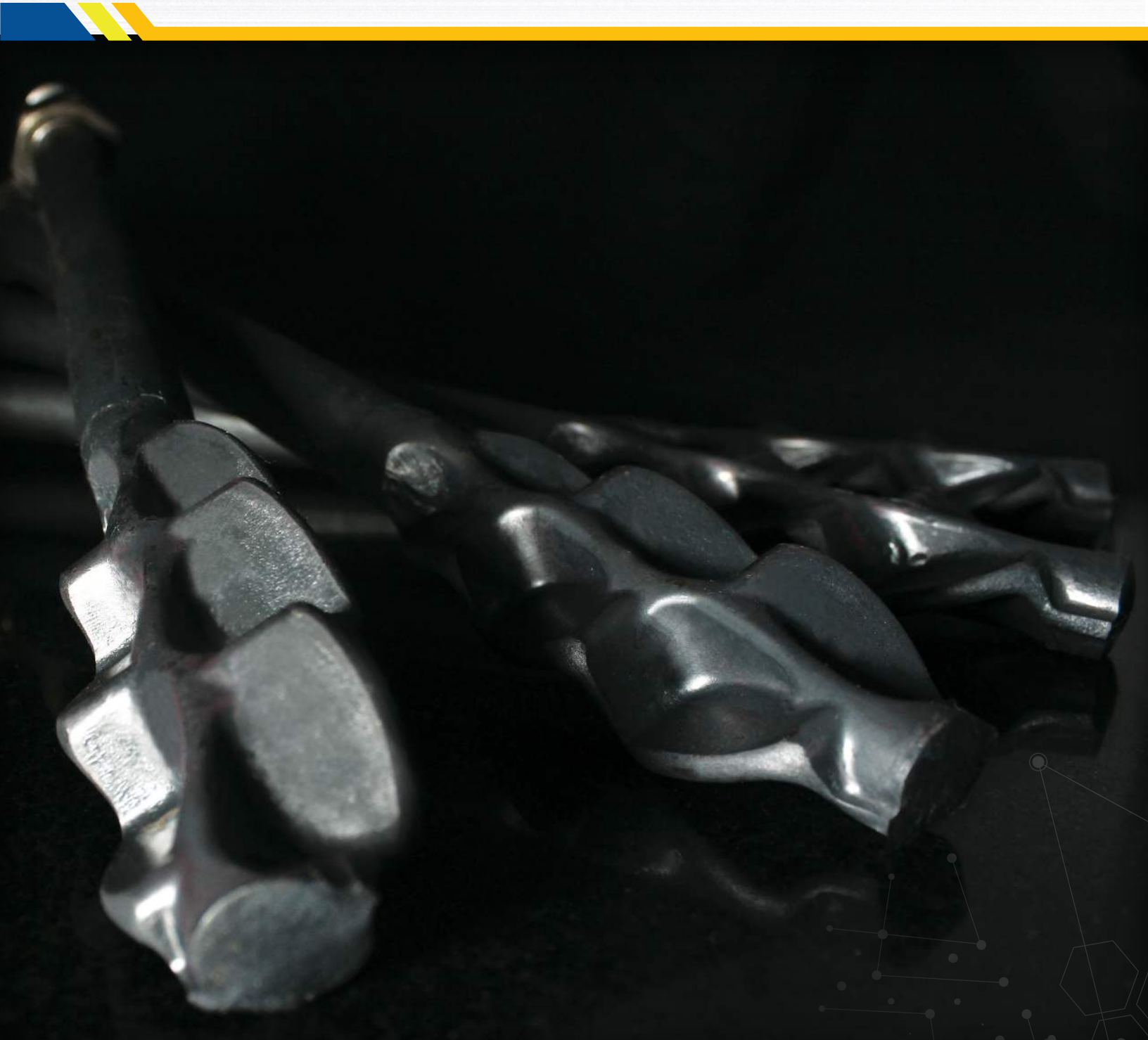

Table of Contents

- 1 UNISORB Vector Bolts**
- 2 Vector Bolt Installation**
- 3 Vector Bolt Options**
 - 3 - Vector Bolt Sizing
 - 4 - Suggested Hole Size
 - 5 - Typical Component Options
 - 6 - UNISORB Vector Collar
 - 7 - Spherical Washer Sets
 - 8 - Typical Grouts
- 9 Proper Grouting Procedure**
- 10 Bulletins**
 - 10 - Anchor Bolts in Concrete (GB-0003-2)
 - 11 - Vector Anchor Bolt Recommended Torque Value (LB-0064-2)
 - 12 - Material Specifications for Vector Anchor Bolts (GB-0049-2)



UNISORB Vector Bolts™

The Vector Bolt Explained

Vector Bolts are designed to generate exceptional holding power. Made of forged steel, Vector Bolts have a series of angular facets which resolve vertical stress forces into a cone-shaped pressure pattern. An additional advantage of this unique design is the greatly increased contact area between the bolt and the grout. The wedge shaped design on the base of the bolt transfers the tensile load of the stud into a lateral compression load in the foundation, assuring maximum pull out strengths. The increase in load transfer to the foundation results in a reduction of the embedment depth required to obtain full strength of the anchor. This reduction in required embedment depths lowers the installation cost by reducing the core drilling and grouting requirements.

Vector Bolts are available in diameters and lengths in a 90,000 psi (6,298 kg/cm²) minimum tensile strength material.



Vector Bolt™ Installation

Typical Layout Concept

1 FOUNDATION PREPARATION — Prepare the foundation in accordance with accepted civil engineering practices. Grout cavities for the Vector Bolts may be provided by pre-casting them or by core drilling after pouring concrete. The best core drilling results can be obtained while the foundation is green (approximately 48 hours).

2 POSITION MACHINE — When the concrete is cured sufficiently to support machine loads, prepare the machine for installation in accordance with the manufacturer's instructions and move into position on the foundation. The machine is supported temporarily on blocks with the anchor holes over the previously prepared grout cavities.

3 ATTACH VECTOR BOLTS — Assemble the Vector Bolts with the spherical washer set and lock collar/o-ring set to the machine base. Position the "O" ring and set collar provided with the anchor bolt against the bottom of the OEM machine leveling puck or adjuster, securing it with the set screw provided. The anchor nut should be positioned so that three threads are exposed and only tightened sufficiently to hold the Vector Bolt in contact with the machine base.

4 LOWER MACHINE — Lower the machine into final position, again supported by temporary blocks with the Vector Bolts® projected into the grout cavities.

5 POUR GROUT — Prepare and pour Unisorb® Grout in accordance with grouting instructions provided with the material. Inset the OEM puck to a 1/4" minimum depth within the grout. If applicable, grout forms used for surface mounting may be removed after grout has set.

6 FINAL SETTING — After grout cures and with anchor nut loose, remove the temporary blocks. Snug anchor nuts with a small hand wrench.

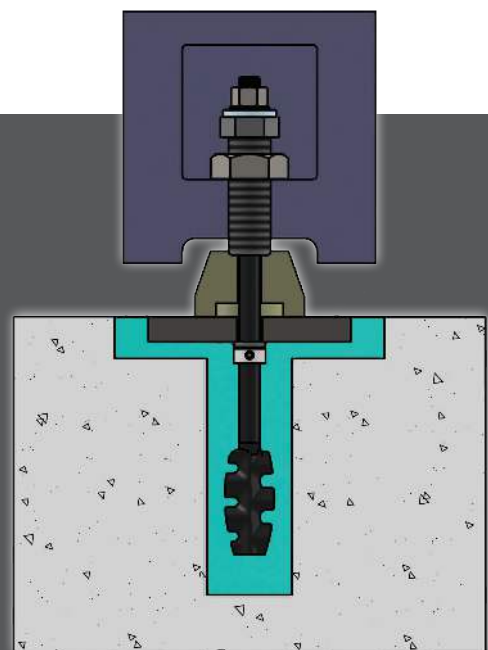
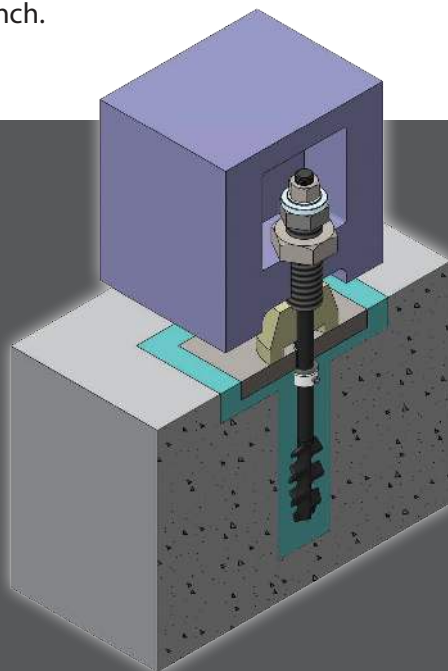
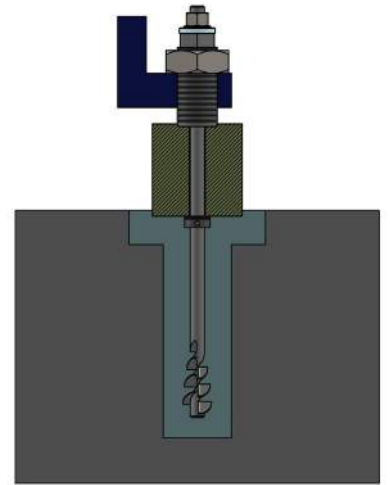

Vector Bolt Sizing

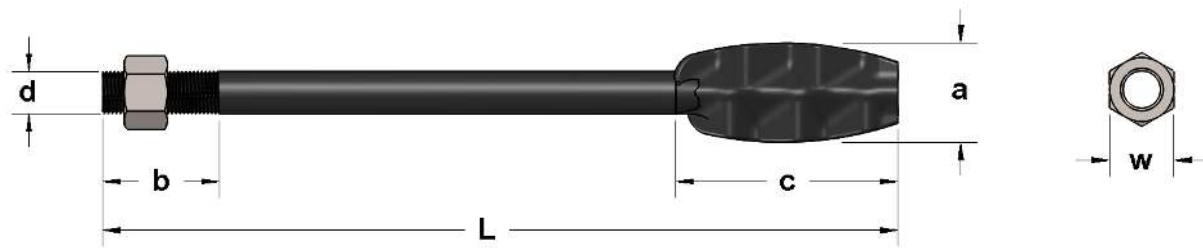

Vector Bolt Diameter & Thread Pitch	Unit of Measure	Basic Dimensions					Standard Length 'L'*							
		d	b	a	c	w								
EM 12 - 1.75	mm	12	30	24	70	19	150	200	-	-	-	-	-	
	Inch	3/8	1	3/4	2-3/4	3/4	6	8	-	-	-	-	-	
EM 16 - 2.00	mm	16	40	32	90	24	150	200	255	300	355	410	460	
	Inch	5/8	1-5/8	1-1/4	3-1/2	.94	6	8	10	12	14	16	18	
EM 20 - 2.50	mm	20	50	40	100	30	200	255	300	350	410	460	-	
	Inch	3/4	2	1-1/2	4	1.2	8	10	12	14	16	18	-	
EM 24 - 3.00	mm	24	60	48	135	36	300	350	410	460	510	610	-	
	Inch	15/16	2-3/8	1-7/8	5-3/8	1.4	12	14	16	18	20	24	-	
EM 30 - 3.50	mm	30	75	60	150	46	320	350	410	460	510	610	-	
	Inch	1-3/16	3	2-3/8	6	1.8	12	14	16	18	20	24	-	
EM 36 - 4.00	mm	36	90	72	180	55	400	610	-	-	-	-	-	
	Inch	1-7/16	3-1/2	2-7/8	7	2.2	16	24	-	-	-	-	-	

* Custom lengths are available upon request. Additional material as well as cut and weld charges will apply.

Suggested Hole Size & Grout Quantity

Grout Type	Vector Bolt Diameter		Minimum Embedment*	Minimum Hole Depth	Minimum Diameter*	Recommended Diameter*
			(Inch/mm)	(Inch/mm)	(Inch/mm)	(Inch/mm)
V-1 Premium Non-Shrink					3.00/76	3.00
Standard V-100 Epoxy	EM 12	—	5.00/305mm	6.00/152mm	1.50/38	2.00
WTF-E V-100 Epoxy					3.00/76	3.00
V-1 Premium Non-Shrink					3.00/76	4.00
Standard V-100 Epoxy	EM 16	—	6.50/165mm	7.50/165mm	1.50/38	3.00
WTF-E V-100 Epoxy					3.00/76	4.00
V-1 Premium Non-Shrink					3.50/89	4.00
Standard V-100 Epoxy	EM 20	—	8.00/203mm	9.00/229mm	2.00/51	3.00
WTF-E V-100 Epoxy					3.50/89	4.00
V-1 Premium Non-Shrink					4.00/102	4.00
Standard V-100 Epoxy	EM 24	—	10.00/254mm	11.00/279mm	2.50/64	3.00
WTF-E V-100 Epoxy					4.00/102	4.00
V-1 Premium Non-Shrink					5.00/127	5.00
Standard V-100 Epoxy	EM 30	—	12.50/318mm	13.50/343mm	3.00/76	3.50
WTF-E V-100 Epoxy					5.00/127	5.00
V-1 Premium Non-Shrink					6.00/152	6.00
Standard V-100 Epoxy	EM 36	—	15.00/381mm	16.00/406mm	3.50/89	4.00
WTF-E V-100 Epoxy					6.00/152	6.00

* Recommended hole sizing can be modified, but must conform to grout capabilities. Consult with Unisorb Engineering to confirm alternative hole sizing.

Notes:

1. Consult Unisorb Engineering to confirm anchor and grout capabilities if punching through the floor in order to achieve minimum embedment depths.
2. For larger volume holes than the above recommendations, V-1 may require the addition of pea stone.
3. For larger volume holes using epoxy grout, a different epoxy grout type with aggregate may be necessary.

Typical Component Options



Vector Bolt

Vector Bolt Anchor includes (1) nut.

Additional nuts are available but sold separately.



Spherical Washer Set

For a non-parallel bearing surface. Ensures full contact with the interface between the machine foot and nut. Includes upper and lower half.

Available in both standard Option p, and Option r Oversized Spherical Washer Sets.



Lock Collar / O-Ring Set

Lock Collar sized to desired Vector Bolt diameter. Includes (1) Lock Collar and (1) O-Ring.

Available for EM16, EM20, EM24, EM30, and EM36 Vector Bolts.



Standard V-100® Epoxy Grout

Consists of (1) epoxy resin pail, (1) epoxy grout hardener pail. Traditional epoxy mixing paddle is sold separately.



V-1® Non Shrink Grout

Consists of (1) 48# bag of cementitious grout.

Optional UNISORB Vector Collar™

The UNISORB Vector Collar, utilized for 16mm and 20mm diameter Vector Bolts, is an essential component in anchoring systems. Used in precision machinery applications to enhance machine stability and repeatability. These collars are secured using a set screw to prevent movement or loosening over time. The collars maintain the anchor integrity by providing resistance against operational forces and vibrations. They are capable of bearing heavy loads and enduring dynamic forces, making them crucial for industrial applications.

Vector Collar Dimensions

Model	Product Code	I.D. Ø	O.D. Ø	Height
VC-167040	450106	18mm	70mm	40mm
VC-207040	450107	22mm	70mm	40mm

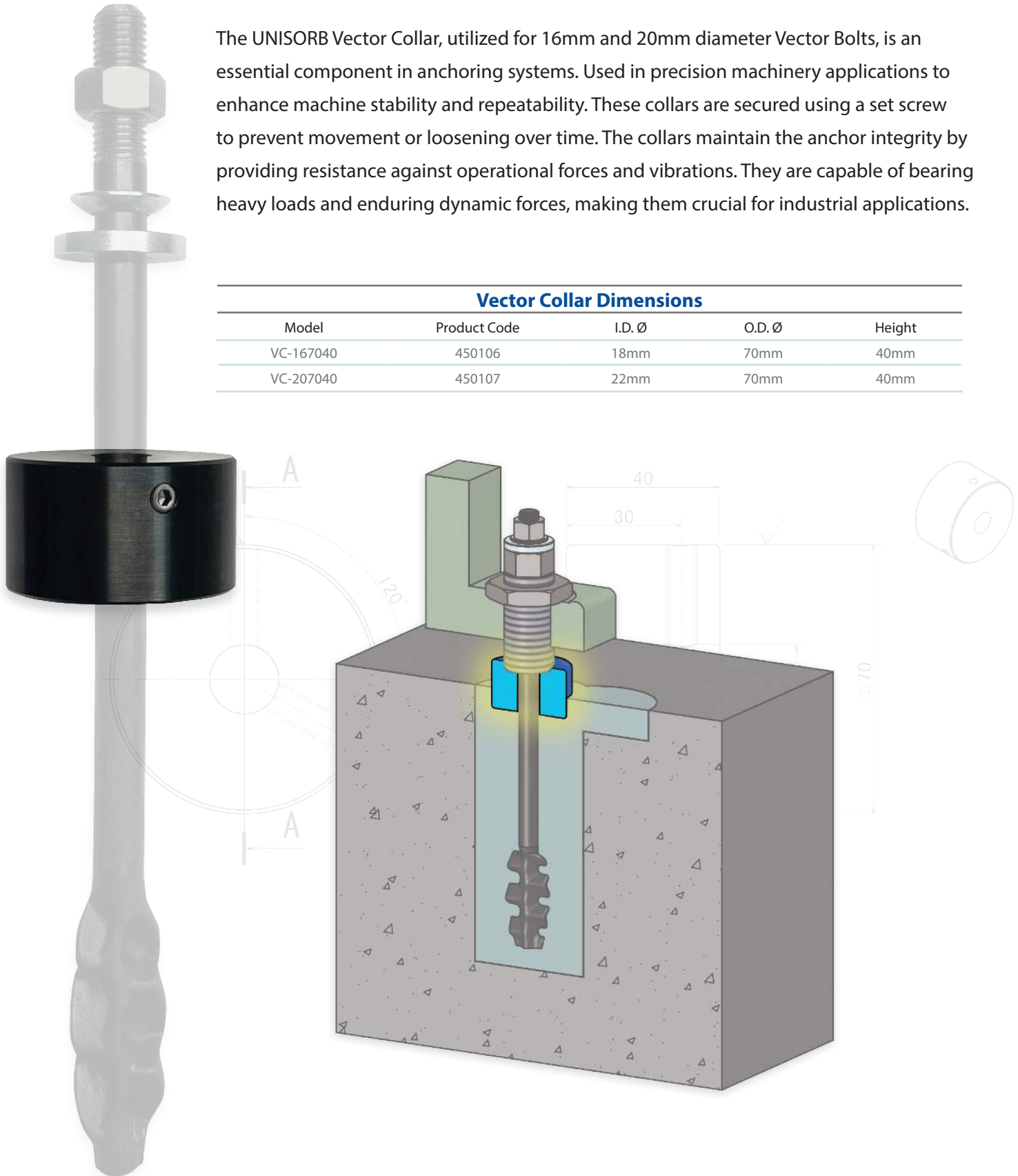

Spherical Washer Sets



For a non-parallel bearing surface. Ensures full contact with the interface between the machine foot and nut. Includes upper and lower half.

Available in both standard Option p, and Option r Oversized Spherical Washer Sets.

p

Spherical Washer Set for non-parallel bearing surfaces.



Option p

Vector Bolt Dia.	DØ	H	dØ	bØ
EM 12	1.57	.35	1.18	.51
EM 16	1.57	.35	1.18	.67
EM 20	1.73	.39	1.42	.83
EM 24	2.20	.51	1.73	.98
EM 30	2.68	.63	2.20	1.22
EM 36	3.07	.79	2.68	1.46

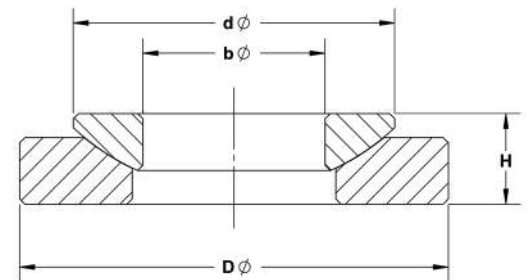

* Max 3° angle correction.

r

Oversized Spherical Washer Set for non-parallel bearing surfaces.



Option r

Vector Bolt Dia.	DØ	H	dØ	bØ
EM 12	1.73	.39	1.42	.67
EM 16	2.20	.51	1.73	.83
EM 20	2.68	.63	2.20	.98
EM 24	3.15	.63	2.20	1.22
EM 30	3.94	.79	2.68	1.46
EM 36	4.92	1.02	3.54	1.73

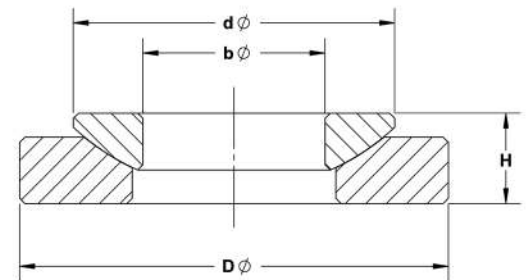

* Max 3° angle correction.

UNISORB Standard V-100 Epoxy Grout

Unisorb's Standard V-100 Epoxy Grout is a high performance, two-component filled epoxy resin system of superior quality that offers excellent flowability, a high resistance to impact and an extremely rapid cure. This grout is the product of choice where ease of placement, suitability for use under extremely high loads, and minimal cross-sectional thicknesses are required. Other materials such as concrete or weaker grouts may develop structural flaws when subjected to high concentrated loads.

Packaging/Yields:

- Standard V-100® Epoxy Grout, 11# Kit (0.10 Cu. Ft.)
- Standard V-100® Epoxy Grout, 22# Kit (0.21 Cu. Ft.)
- Standard V-100® Epoxy Grout, 55# Kit (0.53 Cu. Ft.)



UNISORB V-1 Premium Non-Shrink Grout

Unisorb V-1 Premium Non-Shrink Grout is a cement-based, premixed, highly flowable grout that develops extremely high compressive strengths in a very short period of time.

This product is particularly superior for applications where ease of placement and suitability for use under high unit loads are important. Other materials such as concrete or weaker grouts may develop structural flaws when subjected to concentrated loads.

Unisorb V-1 Premium Non-Shrink Grout is uniquely suited for use in high precision and high load applications ranging from turbines and generators to precision machine tools to equipment base plates. This product contains a special proprietary expansion mechanism which eliminates the natural volume loss present in other cement-based products. This unique expansion mechanism causes expansion primarily during the initial mixing and plastic set stages of the cure, yielding a very stable end product.

Contact Unisorb today with your project details to receive customized guidance that will optimize the installation process and maximize the benefit to your equipment.

Packaging/Yields:

- 48# Bag = .40 Cu. Ft. (691 Cu. In.)



Proper Grouting Procedure

1 PREPARATION — All grout will adhere to whatever it contacts, including debris. Therefore, if the grout is to bond to the concrete, all contact surfaces should be thoroughly cleaned. Cored holes cut through the large aggregate in the concrete and are suitable for grouting after cleaning.

V-1® Cement Based Grout

Cement grout must properly cure, not dry out. After cleaning the concrete surface, the foundation must be saturated with water for 24 hours.

Standard V-100® Epoxy Grout

Epoxy will bond best to a dry surface. Core drilling and all cleaning should be completed with enough time for the concrete to dry before grouting.

2 FORMING — Forms should allow rapid and continuous placement of grout. Forms need to be sealed water tight to the foundation. Good engineering practice is to have the forms placed at a distance from the equipment that is equal to the depth. Excessive areas of grout not under the equipment should be avoided. Allow sufficient space along one edge to place grout. Provide head boxes as required for long flows.

V-1® Cement Based Grout

May be used neat, or extended with pea gravel for thicker pours.

Standard V-100® Epoxy Grout

Two-part epoxy may be used for thinner pours, three-part epoxy for thicker pours. Epoxy will bond to itself, so multiple lifts may be used.

3 TEMPERATURE — In general, grout will cure and develop strength slowly at low temperatures, and cure and develop strength faster at high temperatures.

V-1® Cement Based Grout

Do not allow to freeze. Refer to product data sheet for additional information.

Standard V-100® Epoxy Grout

Specific epoxy formulations are available for temperature extremes. Refer to product data sheet for additional information.

4 PLACEMENT — To assure full support of the equipment, the grout should be placed from one side only, and allowed to flow to the other side, forcing air out ahead of it. The level of grout should be maintained above the bottom of the equipment on the side grout is being placed to avoid air pockets.

V-1® Cement Based Grout

Measure water and never add more water and remix after initial set.

Standard V-100® Epoxy Grout

Epoxy comes in pre-measured kits. Simply mix the resin, continue mixing while adding the hardner. For three-part kits, the aggregate is added last.

5 CURING — Forms should not be removed until after final set.

V-1® Cement Based Grout

Avoid losing water from the fresh grout and stopping the cure cycle. Keep the surface moist with wet rags. Full strength is achieved at 28 days. Consult data sheet for rate of strength development.

Standard V-100® Epoxy Grout

Keep dry. If outdoors, protect from rain until initial set. Full strength is achieved at 7 days. Consult data sheet for rate of strength development.

6 CLEANUP — Different grout types require different cleanup.

V-1® Cement Based Grout

Clean up with water prior to initial set.

Standard V-100® Epoxy Grout

Wipe epoxy off equipment prior to initial set.

ANCHOR BOLTS IN CONCRETE

In the design of a machine tool installation, the anchor bolt plays an important part as a primary element of the machine-to-foundation connection. The function of the bolt is to transfer load from the machine tool base to the foundation. In order to do this, the bolt must be firmly anchored into the concrete foundation and capable of sustaining significant tension loadings in the upward direction.

As we have discussed previously, concrete is not capable of withstanding tensile loadings. Therefore, the anchor bolt must transfer the tensile load applied to it into a compression load in the foundation. In a floating plate anchor like the Unisorb Heavy Duty Jakebolt, this is accomplished by transferring the tensile load into a compression load in the upward direction on the foundation through the bearing plate. In the case of the Vector Bolt, the wedge shaped design on the bottom of the bolt accomplishes this same function. With either of these designs, the mechanism through which concrete failure occurs involves the shearing-out of a cone shaped section (see Figure 1).

For the purposes of calculating the load required to cause this failure, it can be assumed that the tensile load is evenly distributed along the surface of the 45° cone. Knowing the surface area of the cone and the strength of the concrete when loaded in this fashion, it is possible to calculate and accurately predict the point at which this failure may occur. Mathematically, this relationship is expressed in the following manner.

$$L_{po} = A_c K \sqrt{f'_c}$$

L_{po} = Load on anchor at pullout
 A_c = Surface area of shear cone
 K = CONSTANT – Variable depending on concrete mix (3.4 typical)
 f'_c = Compressive force allowable in concrete (3000 psi typical)

The surface area of the cone A_c is calculated from the following relationship:

$$A_c = \pi h \sqrt{2h^2}$$

$$A_c = 3.14h \sqrt{2h^2}$$

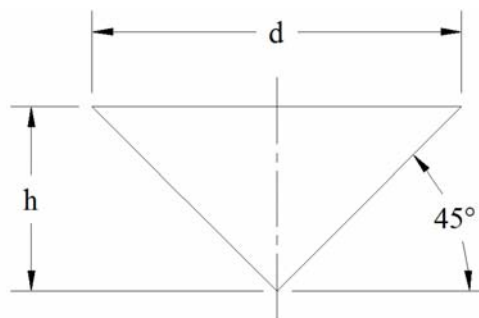

**VECTOR ANCHOR BOLT RECOMMENDED TORQUE VALUES**

Vector Bolt Size	Torque (ft./lbs.)
EM 12	27
EM 16	67
EM 20	130
EM 24	225
EM 30	447
EM 36	781
EM 42	1249
EM 48	1875

These torque values should stress the anchor to a level of 45% to 60% of its yield strength.



MATERIAL SPECIFICATIONS FOR VECTOR ANCHOR BOLTS

Chemical Composition:

"C"	=	0.42 to 0.050%
"Si"	=	0.15 to 0.35%
"Mn"	=	0.50 to 0.80%
"P"	=	0.045% max
"S"	=	0.045% max

Physical Properties:
(for 5/8" to 2" Dia.)

Tensile	=	93,000 to 109,000 psi
Yield	=	58,000 to 67,000 psi
Elong.	=	14% to 18% within 5 D min.

Material Grade: C - 45 (German)