



INSTALLATION SOLUTIONS

QUANTUM IM™ MOUNTS



4117 FELTERS ROAD, MICHIGAN CENTER, MI 49254
517-764-6060 • 888-486-4767
www.UNISORB.com

www.UNISORB.com



UNISORB IM™ Mounts Benefits

- Reduction of Shock and Vibration
- Prevention of Machine “Walking”
- Simplification of Machine Installation
- Elimination of Anchor Bolts
- Fast, Accurate Alignment
- Increased Equipment Life
- Compensation for Horizontal Impact/Force
- Accommodation of Uneven Floors

For Injection Molding and Die Casting Machines



UNISORB IM™ Mounts

UNISORB's patented line of Quantum IM Mounts has been thoroughly engineered and tested to accommodate injection molding and die casting machines of any size. From the smallest of machines to large 4,500 ton machines, Quantum IM Mounts are the most durable mounts available.

The **Maximum Adjustment Range** of these mounts truly represents a quantum leap in mount technology. Every model size in the line provides an **overall height adjustment range of 1-3/8"/35mm**. This range goes well beyond that of UNISORB's competitors worldwide. In addition, Quantum IM Mounts are available in a wide variety of sizes and configurations, and they all share these time tested durability features:

- Rugged Ductile Housing
- Super Heavy-Duty Impact Plate
- Resilient Anti-Walk Isolation Pad
- High-Strength Steel Adjusting Bolt
- Constant Horizontal Natural Frequency

The **Housing and Impact Plate** are made of ductile iron, meeting Foundry Specification 65045-12. Our product team has tested and proven this design to be virtually indestructible, even in the toughest high-speed injection molding applications.

The **Isolation Pad** consists of a proprietary nitrile rubber compound. The unique internal design of UNISORB's Quantum IM Mount eliminates interdependence between vertical adjustment and horizontal stiffness found in other mount designs. Our design ensures that each mounting point presents identical horizontal and vertical load deflection characteristics to the machine regardless of adjustment height.

The high-strength ISO Grade 8.8 hex head **Adjusting Bolt** is capable of withstanding punishment that would shear off most other bolts. In addition, the finer thread pitch on the adjusting bolt provides greater mechanical advantage and offers a higher degree of accuracy in adjustment, making installation convenient and foolproof. Standard bolts are provided with Metric threads and special bolt lengths are available on request.

The isolation pad is **Precision Engineered for Horizontal Impact**. With a precision fit inside the housing, this tight fitting design yields smoother, quieter operation and longer mount life. The sure fit of the isolation pad enhances the mount's ability to absorb the horizontal impact forces caused by machine operation.

The unique patented design of the isolation pad to mount housing interface results in a condition where **Weight and Force are Distributed evenly**. This uniform distribution of applied forces means that Quantum IM Mounts are unmatched in controlling extreme machine induced dynamic loads. This eliminates the walking, excessive machine motion, and mount failures typical of general purpose mounts in these difficult applications.

The rectangular shape of the mount **Prevents Machine Walking**, thus providing still another advantage. While providing greater resistance to machine walking than circular mounts, the straight, leading edge surface on the rectangular mount has proven to be more geometrically stable. This helps to eliminate pad roll and entrapment of coolants and oils beneath the pad. In addition, each isolation pad is engineered to possess an exceptionally high coefficient of friction that also helps to prevent machine walking.

The Quantum IM Mount provides **Constant Horizontal Natural Frequency**, which means that consistent performance will be achieved at any adjustment height. This is an important feature which is only available with these mounts.

Quantum IM Mounts provide **Accommodation of Uneven Floors**. The plate and housing are designed to interact with the isolation pad and the hex head adjusting bolt to yield optimum performance, even when floors are severely out of level.

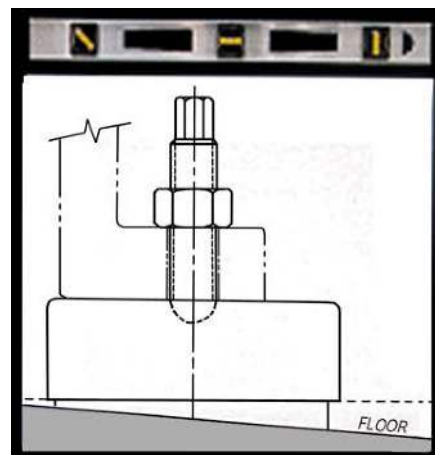

QUANTUM IM MOUNTS

Mount	Product Code	Length in./mm	Width in./mm	Height Min.-Max. in./mm	Bolt Size: (Metric)	Max. Load lbs./kg
IM-51-M12-N90	475806	5.50/140	3.50/89	2.50-3.88/64-99	M12x1.75x150	3000/1361
IM-51-M16-N90	475807	5.50/140	3.50/89	2.50-3.88/64-99	M16x2x150	3000/1361
IM-61-M16-N90	475816	7.00/178	4.50/114	2.50-3.88/64-99	M16x2x150	6000/2722
IM-62-M20-N90	475817	7.00/178	4.50/114	2.50-3.88/64-99	M20x1.5x150	6000/2722
IM-61-M24-N90	475818	7.00/178	4.50/114	2.50-3.88/64-99	M24x2x150	6000/2722
IM-71-M20-N90	475827	8.00/203	5.00/127	2.50-3.88/64-99	M20x1.5x150	9000/4082
IM-71-M24-N90	475828	8.00/203	5.00/127	2.50-3.88/64-99	M24x2x150	9000/4082
IM-81-M20-N90	475830	8.00/203	5.88/149	2.50-3.88/64-99	M20x1.5x150	9000/4082
IM-81-M24-N90	475833	8.00/203	5.88/149	2.50-3.88/64-99	M24x2x150	12000/5443
IM-81-M24-NTS	475839	8.00/203	5.88/149	2.50-3.88/64-99	M24x2x150	16000/7257
IM-81-M30-NTS	475840	8.00/203	5.88/149	2.50-3.88/64-99	M30x2x150	16000/7257
IM-101-M24-NTS	475841	10.00/254	7.88/200	3.25-4.683/83-117	M24x2x200	16000/7257
IM-101-M30-NTS	475842	10.00/254	7.88/200	3.25-4.683/83-117	M30x2x230	25000/11340
IM-101-M36-NTS	475843	10.00/254	7.88/200	3.25-4.683/83-117	M36x2x270	25000/11340
IM-121-M24-NTS	475853	12.50/318	9.00/229	3.50-4.88/89-124	M24x2x200	16000/7257
IM-121-M30-NTS	475855	12.50/318	9.00/229	3.50-4.88/89-124	M30x2x230	25000/11340
IM-121-M36-NTS	475857	12.50/318	9.00/229	3.50-4.88/89-124	M36x2x270	35000/15876
IM-121-M42-NTS	475860	12.50/318	9.00/229	3.50-4.88/89-124	M42x2x300	35000/15876
IM-161-M30-NTS	475862	16.00/406	12.50/318	4.50-5.88/114-149	M30x2x230	25000/11340
IM-161-M36-NTS	475863	16.00/406	12.50/318	4.50-5.88/114-149	M36x2x270	35000/15876
IM-161-M42-NTS	475865	16.00/406	12.50/318	4.50-5.88/114-149	M42x2x300	46000/21772
IM-161-M48-NTS	475867	16.00/406	12.50/318	4.50-5.88/114-149	M48x2x300	60000/27216
IM-161-M56-NTS	475871	16.00/406	12.50/318	4.50-5.88/114-149	M56x2x300	60000/27216

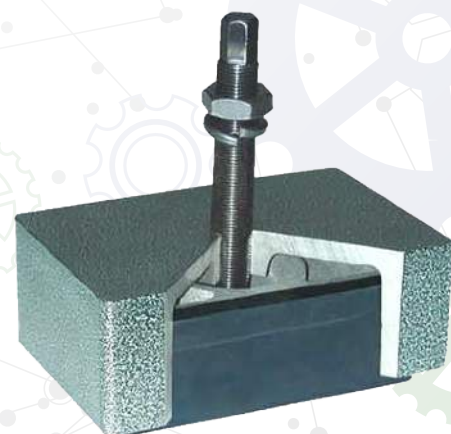

CUTAWAY VIEW OF IM-61 MOUNT

Other UNISORB products for use with Injection Molding and Die Casting Machines

The **UNISORB Fixator** is designed specifically for support critical applications. Some examples include larger multiple component machines which require support from a specially engineered foundation to maintain alignments. The Fixator makes installations fast and easy while aligning machines to $\pm .0001$ "/ $.00254$ mm tolerances. Finely machined Molykoted surfaces, limited backlash, and high mechanical advantage makes adjustment easy-even under heavy loads.

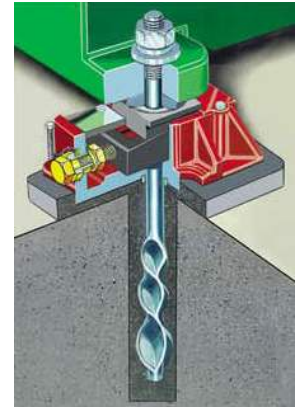

FIXATOR

UNISORB Tri-Wedge Mounts come in two model sizes, the TW-8000 and TW-35000. The Model TW-35000 is available with an optional mounting stud as shown. The model names depict load capacities in lbs. These mounts provide a very broad load capacity range to handle a wide variety of applications including Injection Molding and Die Casting machines. They have a wide min./max. height adjustment range not available with most wedge type mounts. The mounts have two height ranges available, achieved by positioning a retainer within the mount. Both mounts come with high friction, oil resistant Nitrile rubber pads. Extensive testing has proven the pads to be highly effective in preventing machines from walking, with a high coefficient of friction. The pad formula is designed to be highly resistant to oil and other industrial compounds to insure long application life. They also provide isolation from vibrations.



TW-8000



**TW-35000
W/STUD**

Machine Installation Expertise Since 1935

Since 1935 UNISORB has been serving the machinery installation needs of all segments of the manufacturing industry. As a part of our commitment to provide the best installation products and services, UNISORB maintains the only industry staff of engineers devoted exclusively to the design and implementation of complete machinery installation systems. From concept to final installation, UNISORB ensures optimum performance of mounted equipment.

Depend on UNISORB's years of experience for:

- Machinery Mounts
- Vibration Isolation Systems
- Anchoring/Alignment Systems
- Vibration Analysis Services
- Professional Engineering Services
- Isolated Foundation Design
- Advanced Grouting Technologies