



INSTALLATION TECHNOLOGIES

# DATA SHEET

## VIBRALASTIC™ TYPE VM MOUNTS

Bulletin No.  
GB-0156-1.1  
1/24/11

Vibralastic Type VM Mounts are designed for applications with low frequency vibrations. They are also excellent for shock attenuation because they offer large deflection capability. These mounts offer passive vibration isolation for measuring equipment, test cells and electronic instruments.

Type VM Mounts are designed to provide a large degree of deflection at low loads. Even though this mount design provides high amount of deflection, it is compact, light weight, and features easy installation.

Typical applications are as follows:

- Fans
  - Electric motors
  - Packaging applications
  - Compressors
  - AC units
  - Weighing scales
  - Vibratory screens
  - Measuring equipment
- Pumps
  - Test cell equipment
  - Ventilators
  - Refrigeration units
  - Powder handling machinery
  - Noise control units
  - Food processing equipment
  - Electronic instruments

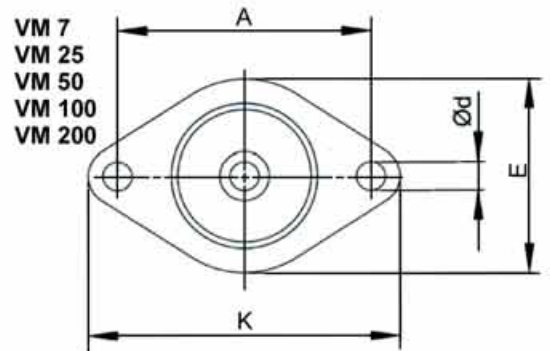
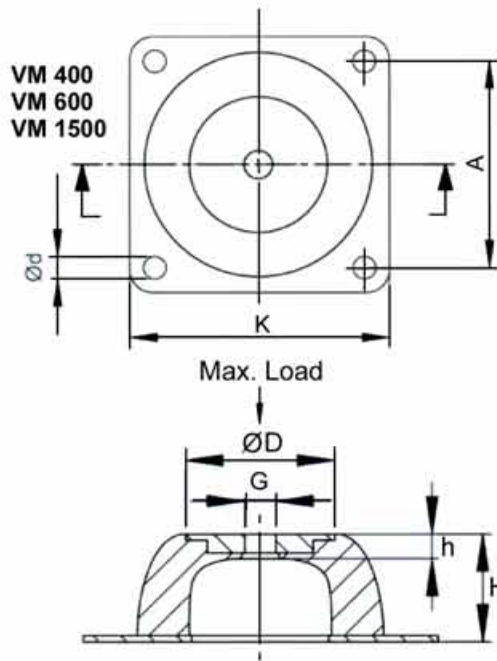

Vibralastic Type VM

TYPE	D	E	A	K	H	h	d	G	MAX. LOAD 40 D.	MAX. LOAD 60 D.	WEIGHT
VM 7	18	43	50	64	20	7	7.0	M6	3.5	9	0.020
VM 25	27	56	66	85	25	11	8.0	M8	25	50	0.070
VM 50	40	76	92	114	35	14	10.0	M10	40	80	0.160
VM 100	44	96	110	136	40	15	11.5	M10	70	150	0.260
VM 200	54	101	124	151	45	13	11.5	M10	130	220	0.420
VM 400	78	-	120	150	63	18	14.5	M12	280	500	1.060
VM 600	100	-	160	200	85	25	14.5	M16	380	750	2.350
VM 1500	186	-	250	310	160	43	18.0	M24	1400	2500	9.430

Dimensions are in millimeters. Weights and loads are in kilograms.

# VIBRALASTIC™ TYPE VM MOUNTS

NATURAL FREQUENCY (HZ)

LOAD DEFLECTION (MM)

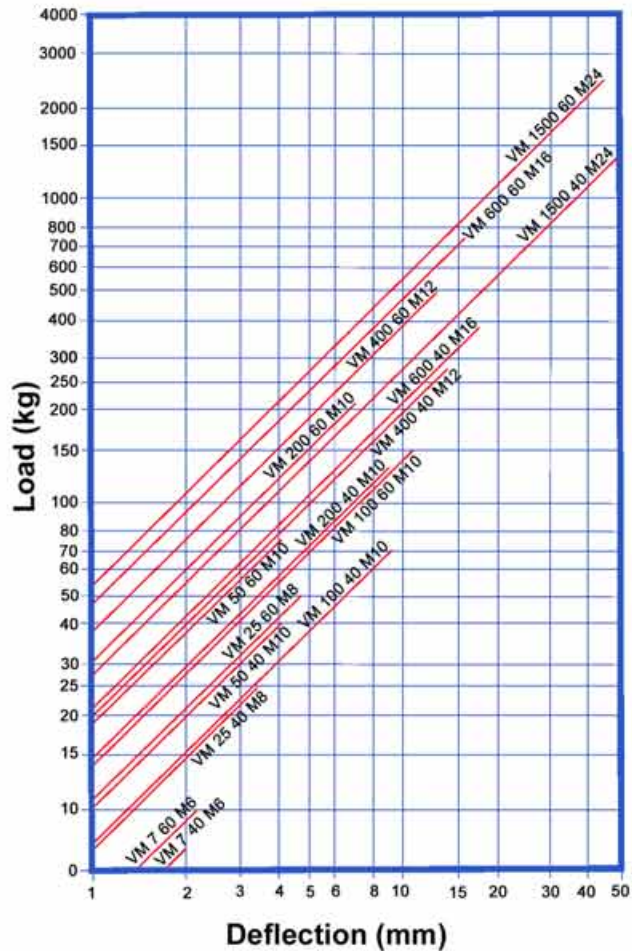
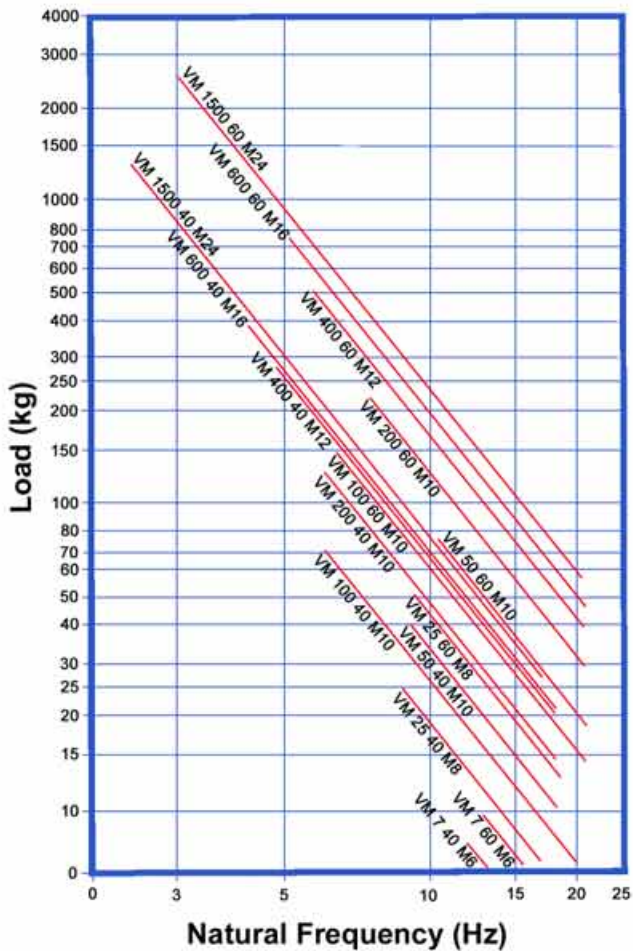

INSTALLATION TECHNOLOGIES

[www.unisorb.com](http://www.unisorb.com)

BOX 1000, JACKSON, MI 49204-1000

888-4-UNISORB • FAX 517-764-5607

ISO-9001:2000 Certified