

# UNISORB® LEVEL-RITE® MACHINERY MOUNTS



U.S. PATENT NO. 5,794,912

**FULL**  
**1-3/8"**  
**(35mm)**  
**ADJUSTMENT**  
**RANGE**

UNISORB'S line of LEVEL-RITE mounts are superbly engineered, unbreakable, and perfectly suited for general purpose machine leveling and isolation usage. Both the housing and impact plate of the UNISORB LEVEL-RITE mounts are made of ductile iron, conforming to Foundry Spec. 65-45-12. Every UNISORB LEVEL-RITE mount provides an overall height adjustment of 1-3/8 inches (35mm)- well beyond all similar products around the world. Additionally, UNISORB LEVEL-RITE mounts yield optimum performance, even with floors that are uneven.

The isolation pads of all UNISORB LEVEL-RITE mounts are made from proprietary elastomers. The unique internal design eliminates the interdependence between vertical and horizontal stiffness found in other mount designs. This unique design ensures that each mounting point presents consistent vertical and horizontal load deflection characteristics, regardless of adjustment height. LEVEL-RITE mounts are unmatched in controlling extreme machine induced dynamic loads, thus eliminating excessive machine motion and preventing failures typical of most other general purpose mounts.

The LEVEL-RITE mount features a high strength, grade 5 hex. head adjusting bolt that will withstand punishment which would shear off most other bolts. LEVEL-RITE mounts feature adjusting bolts with metric threads. The finer thread pitch provides greater accuracy in adjustment. Special bolt lengths and configurations are available on request.

The rectangular shape of the UNISORB LEVEL-RITE mounts provides another important advantage. While providing greater resistance to walking than circular mounts, the straight leading edge surface on the rectangular mounts has proven to be more geometrically stable. This helps eliminate pad roll and entrapment of coolants and oils beneath

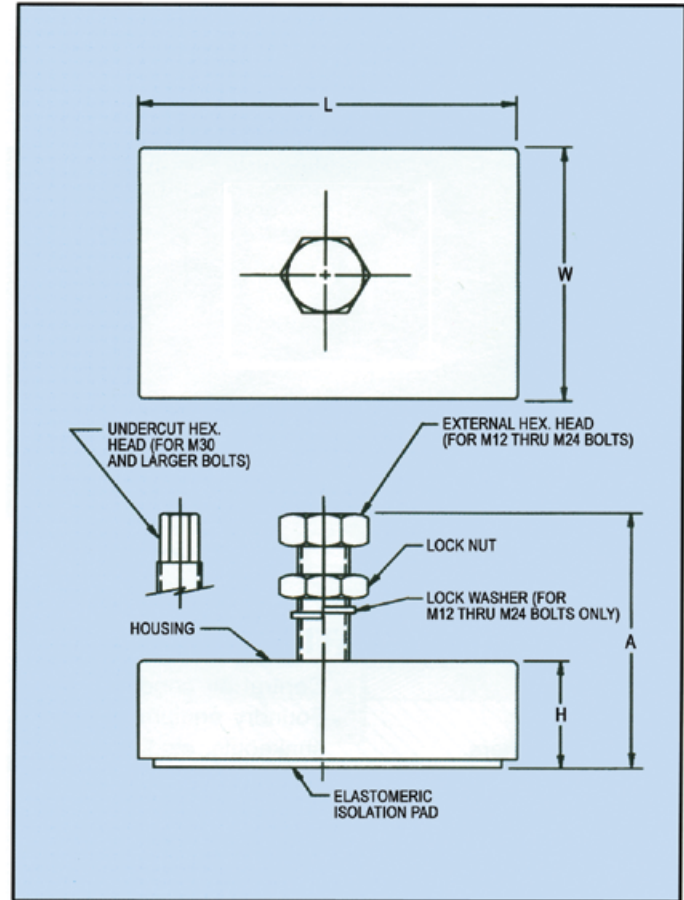

the pad. The exceptionally high coefficient of friction provided by these elastomeric pads also prevents machine walking.

Mount loadings are expressed in pounds and kilograms as shown in the chart below. To determine the approximate load applied by a particular machine, divide the total weight by the number of mounting points. Note that in certain cases, where weight distribution may load one or more mounts significantly more than others, special consideration is required. When machinery generating high impact is being mounted, reduce the mount rating by 25% to assure maximum performance.

SPECIFICATIONS									
LEVEL-RITE MOUNT	PRODUCT CODE	MAX. LOAD lbs./kg	A in./mm	L in./mm	W in./mm	H MIN./MAX.		STANDARD BOLT SIZE	MAX. MACH. FOOT TH. in./mm
						in.	mm		
LR-2500	574200	2500/1136	7.78/198	5.50/140	3.50/89	2.50/3.88	64/99	M12 x 1.75 x 150	2.27/58
LR-5000	574300	5000/2273	7.77/197	7.00/178	4.50/114	2.50/3.88	64/99	M16 x 2 x 150	2.08/53
LR-7500	574400	7500/3409	7.88/200	8.00/203	5.00/127	2.50/3.88	64/99	M20 x 1.5 x 150	1.91/49
LR-12000	574500	12000/5455	9.94/252	8.00/203	5.88/149	2.50/3.88	64/99	M24 x 2 x 150	3.65/93
LR-16000	574600	16000/7273	10.32/262	10.00/254	7.88/200	3.25/4.62	83/117	M24 x 2 x 150	3.40/86
LR-25000	574700	25000/11364	10.74/273	12.50/318	9.00/229	3.50/4.88	89/124	M30 x 2 x 200	3.53/90
LR-35000	574800	35000/15909	11.09/282	16.00/406	12.50/318	4.50/5.88	114/149	M36 x 2 x 250	4.52/115

For mounts with higher load capacities contact UNISORB Engineering.